

UMENT AND THE INFORMATION IT
HAVE BEEN FURNISHED FOR USE
BY OWN ORGANIZATION ONLY AND
FOR PURPOSE CONSISTENT WITH THE
AGREEMENT BETWEEN YOUR ORGANIZATION
AND KANSAS CITY DEAERATOR COMPANY.
KANSAS CITY DEAERATOR COMPANY
WILL NOT BE RESPONSIBLE FOR ANY
PARTY WITHOUT THE WRITTEN
CONSENT OF KANSAS CITY DEAERATOR CO.,
2400 LAND PARK, KANSAS 66209

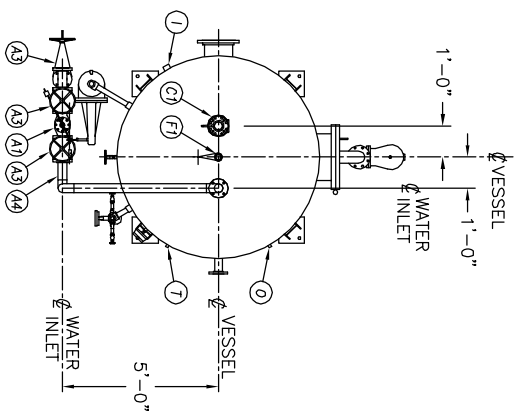

TOP VIEW

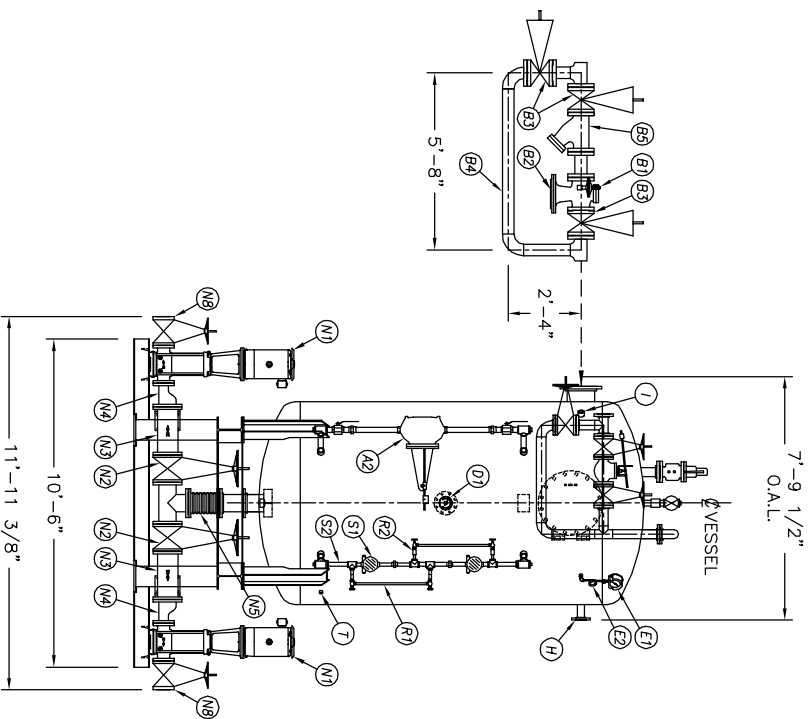

FRONT VIEW

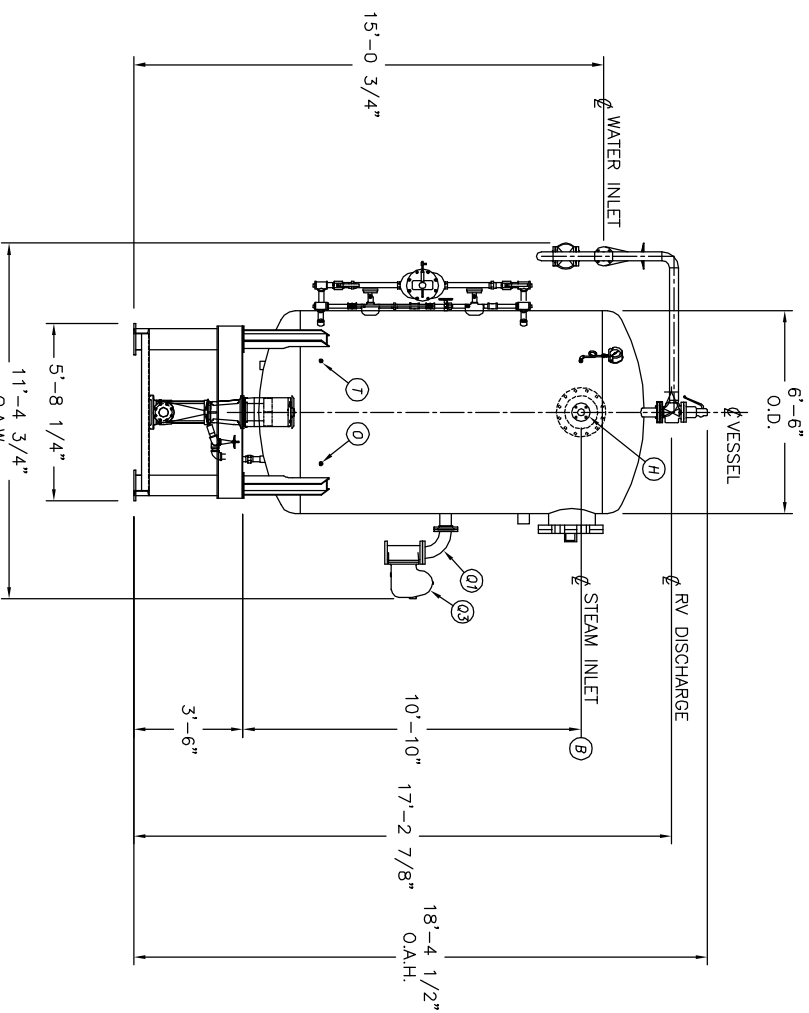

END VIEW

A1	INLET VALVE		NONE	
A2	CONTROL		NONE	
A3	3 BYPASS VALVES	2	NIBCO	T-111
A4	1 MAKE UP BY-PASS PIPING	2	KOD SHOP	
A5	STRAINER		NONE	
B1	STEAM PRV		NONE	
B2	STEAM CONTROLLER		NONE	
B3	BYPASS VALVES		NONE	
B4	STEAM PRV BY-PASS PIPING		NONE	
B5	1 STRAINER	3	MUELLER	782
C1	RELIEF VALVE		NONE	
C2	RELIEF VALVE PIPING		NONE	
D1	THERMOWELL		NONE	
E1	PRESSURE GAUGE		NONE	
E2	SIPHON & COCK		NONE	
E3	PRESSURE TRANS		NONE	
F1	VENT VALVE		NONE	
F2	1 ORIFICE PLATES	#N/A	#N/A	
F3	BYPASS VALVES		NONE	
F4	IMV SPARE GASKETS		NONE	
G1	IMV SPARE GASKETS		NONE	
H1	VACUUM BREAKER		NONE	
M1	BFP RECIRC SHUTTOFF		NONE	
M2	BFP RECIRC CHECK		NONE	
M3	BFP ORIFICE / VALVE		NONE	
M4	BFP PIPING		NONE	
M5	BFP PRESSURE GAUGE	4	GRUNDFOS	CR60-50U
M1	2 BOILER FEED PUMPS	4	NIBCO	F817.0
N2	ISOLATION VALVE	4	MUELLER	788
N3	2 STRAINER	4	KOD SHOP	
N4	2 PIPING	4		
N5	2 EXPANSION JOINT	4		
N6	BFP DISC PRESSURE GAUGE			
N7	BFP DISC CHECK			
N8	BFP DISCH ISOLATION			
O	CHEMICAL FEED QUILL		NONE	
P	IMV SPARE GASKETS		NONE	
Q1	OVERFLOW VALVE		NONE	
Q2	CONTROL		NONE	
Q3	OVERFLOW PIPING		NONE	
R1	LEVEL SWITCHES	1 1/2	NONE	
R2	1 LEVEL SWITCH BRIDLE PIPING	1 1/2	NIBCO	T-111
S1	GAUGE GLASS		NONE	
S2	1 GAUGE GLASS BRIDLE PIPING	1 1/2	NIBCO	T-111
T1				
2	CONTROL PANEL			
	STARTERS	NONE		
1	PUMP STAND	14.2		

NOTE:
CUSTOMER TO FIELD ALIGN PUMPS
AND MOTORS, THEN SEND KCD
CERTIFICATION PAPERS.

NO.	DATE	DESCRIPTION OF CHANGE	BY
-	-	-	-
-	-	-	-
-	-	-	-

CLIENT:

KANSAS CITY DEAERATOR CO.
6731 W. 121st STREET
OVERLAND PARK, KANSAS 66209
(913) 338-2111 FAX (913) 338-2144

JOB #	SCALE	DESIGNED	DRAWN	CHECKED	DATE	UTD
STD	NTS	MK	GENI	PC	10-20 2003	10-20 2003

TITLE: **GENERAL ARRANGEMENT**

MODEL: VSP-6510-090

DWG. NO.: **VSP6510-090-CR45-4**